

PART NUMBER	LENGTH (MM)	LENGTH (INCH)
HT0150	90	3.543
HT0152	95	3.740
HT0154	100	3.937
HT0156	110	4.330
HT0158	120	4.724
HT0160	130	5.118
HT0162	140	5.511
HT0164	150	5.905
HT0166	160	6.299
HT0168	170	6.692
HT0170	180	7.086

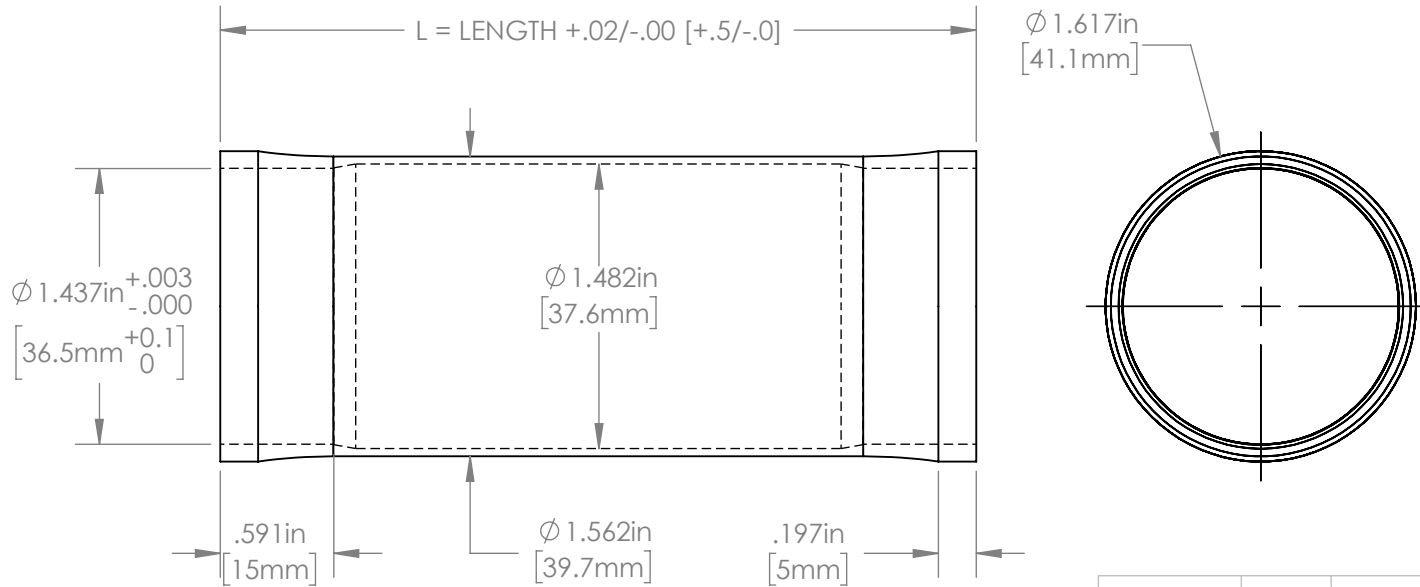
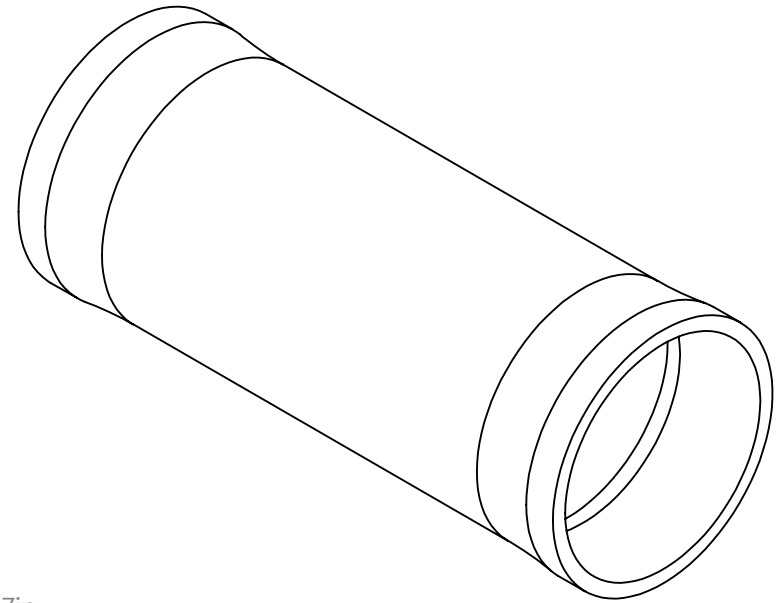

PARAGON MACHINE WORKS

TITLE:

**EC37/EC37
TITANIUM HEADTUBE**

	NAME	DATE
DRAWN BY:	CAN	8/23
CHECKED BY:	JAS	8/23

MATERIAL:
GENERAL TOLERANCES:
 X.X ± 0.020"
 X.XX ± 0.010"
 X.XXX ± 0.005"

SIZE	DWG. NO.	REV
A	HT01XX	A1

SCALE: 1:2

SHEET 1 OF 1

**PROPRIETARY AND
CONFIDENTIAL**

THE INFORMATION CONTAINED IN THIS DRAWING IS PROVIDED FOR FRAMEBUILDERS AND IS THE PROPERTY OF PARAGON MACHINE WORKS. ANY REPRODUCTION IN PART OR AS A WHOLE WITHOUT THE WRITTEN PERMISSION OF PARAGON MACHINE WORKS IS PROHIBITED.