

PART NUMBER	WIDTH (NOMINAL)	W	W
FT1100	100 mm	100 mm	3.937 in
FT1108	110 mm	110 mm	4.331 in

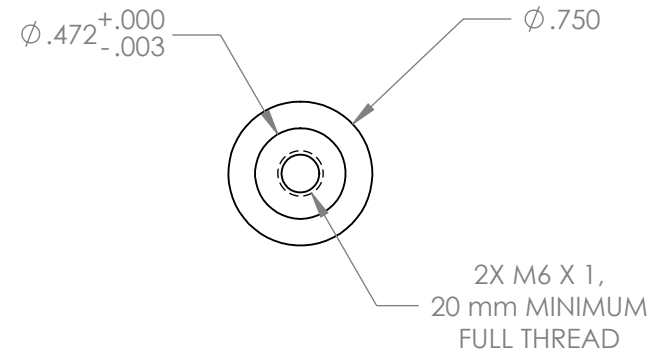
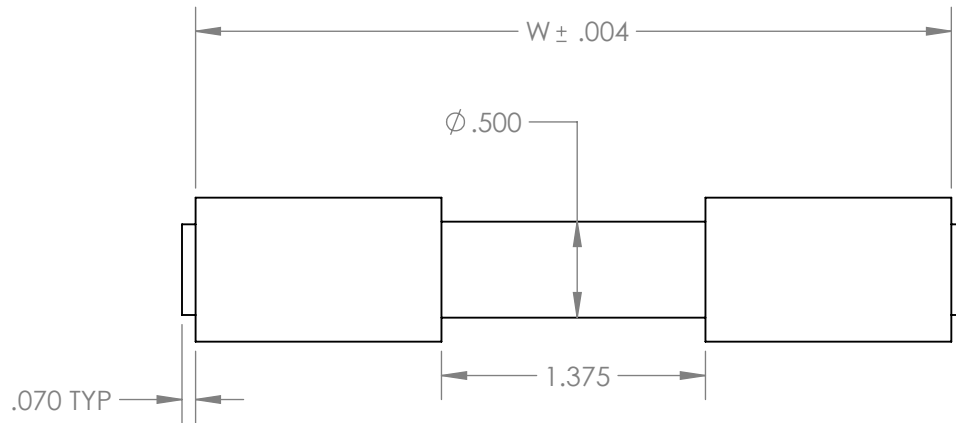

PARAGON MACHINE WORKS

TITLE:

12 mm, FRONT SPACER

	NAME	DATE
DRAWN BY:	CN	4/20
CHECKED BY:	MN	4/20

MATERIAL:
GENERAL TOLERANCES:
 X.X ± 0.020"
 X.XX ± 0.010"
 X.XXX ± 0.005"

PROPRIETARY AND CONFIDENTIAL
 THE INFORMATION CONTAINED IN THIS DRAWING IS PROVIDED FOR FRAMEBUILDERS AND IS THE PROPERTY OF PARAGON MACHINE WORKS. ANY REPRODUCTION IN PART OR AS A WHOLE WITHOUT THE WRITTEN PERMISSION OF PARAGON MACHINE WORKS IS PROHIBITED.

SIZE	DWG. NO.	REV
A	FT1100_08	A

SCALE: 2:3

SHEET 1 OF 1