

COMPATIBLE FRAME COMPONENTS		
6/4 TITANIUM	17/4 STAINLESS	DESCRIPTION
DS0030BD	DS1030BD	No Eyelets, Belt Drive
DS0030	DS1030	No Eyelets
DS0035	DS1035	Eyelets
DS0035BD	DS1035BD	Eyelets, Belt Drive
DS0090	DS1090	Full Thickness, No Eyelets
DS0091	DS1091	Full Thickness, Eyelets
ITEM NO.	PART NO.	EXPLODED VIEW
1	MS1016	Pin
2	MS1014	M8 Washer, Stainless Steel
3	MS2015	M8 x 1.25 x 16 BHCS, Zinc Plated Steel
4	DR4096 (Bare) B4096 (Black)	Hanger for SRAM Derailleur
5	DS0035	6/4 Titanium Frame Component, Eyelets
6	DS0050 (6/4 Titanium) DS1050 (17/4 Stainless) DS1055 (17/4 Stainless)	DS0050: 5/8" x .035" Seatstay Kit DS1050: 5/8" x .035" Seatstay Kit DS1055: M12 x 1 Seatstay Kit

See website for additional inserts. Inserts and frame components sold separately.

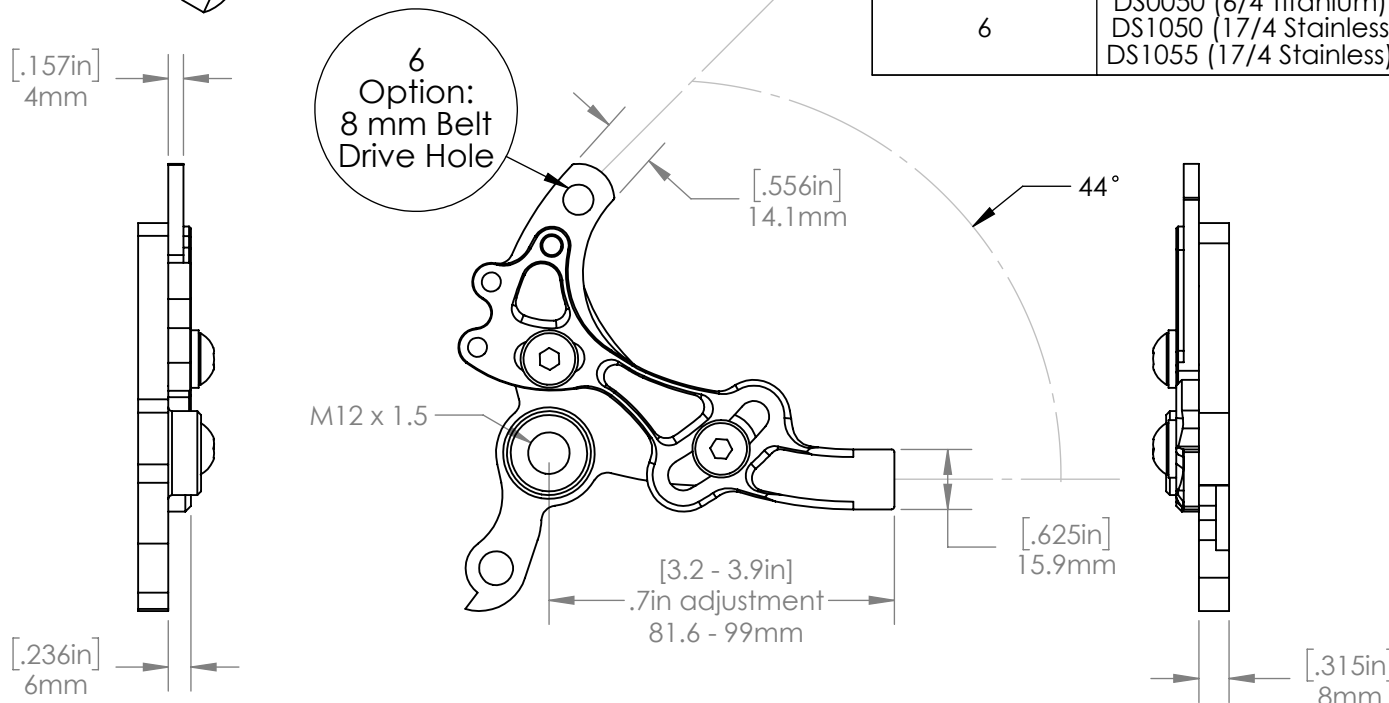

PARAGON MACHINE WORKS		
TITLE: Right Side Insert, Rocker, SRAM Derailleur, 12 mm Hub		
SIZE	DWG. NO.	REV
A	DR4096	A1
SCALE: 1:2		SHEET 1 OF 1

	NAME	DATE
DRAWN BY:	DN	2/2020
CHECKED BY:	MCN	2/2020

MATERIAL:
GENERAL TOLERANCES:
 X.X ± 0.020"
 X.XX ± 0.010"
 X.XXX ± 0.005"

PROPRIETARY AND CONFIDENTIAL
 THE INFORMATION CONTAINED IN THIS DRAWING IS PROVIDED FOR FRAMEBUILDERS AND IS THE PROPERTY OF PARAGON MACHINE WORKS. ANY REPRODUCTION IN PART OR AS A WHOLE WITHOUT THE WRITTEN PERMISSION OF PARAGON MACHINE WORKS IS PROHIBITED.