

**EXPLODED VIEW**

ITEM NO.	PART NO.	DESCRIPTION	MATERIAL
1	DS0001	Flanged	6/4 Titanium
2	DR4075 (Bare) B4075 (Black)	No ISO Mount	6061 Aluminum
3	MS1013	Double Washer	Stainless Steel
4	MS2012	M8 x 1.25 x 18 BHCS	Zinc Plated Steel
5	MS2013	M5 x 0.8 SHCS	Steel
6	MS2016	M5 Hex Nut	Steel
7	MS5001	BRASS THUMB NUT	Brass

**COMPATIBLE FRAME COMPONENTS**

6/4 TITANIUM	17/4 STAINLESS	DESCRIPTION
DS0001	DS1001, DS1007	Flanged
DS0004	DS1004	Flat
DS0004BD	DS1004BD	Flat, Belt Drive

See website for additional inserts.  
inserts and frame components  
sold separately.

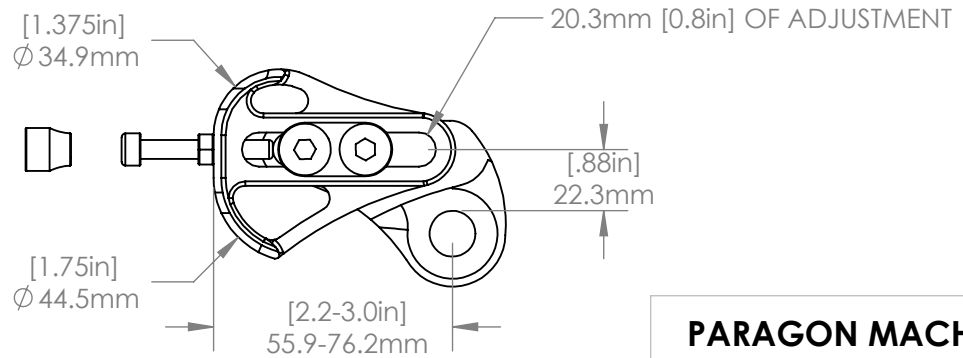
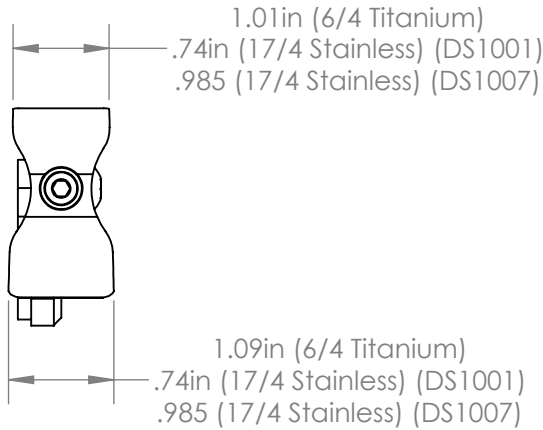
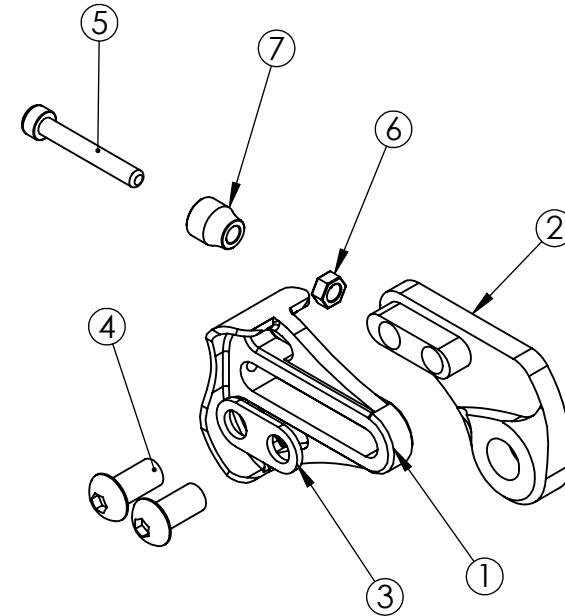

**PARAGON MACHINE WORKS**

TITLE:  
Left Side Insert, Sliding,  
No ISO Mount, 12 mm Hub

	NAME	DATE
DRAWN BY:	L.L	9/24

CHECKED BY:  
MATERIAL: 6061 ALUMINUM  
GENERAL TOLERANCES  
X.X ± 0.020"  
X.XX ± 0.010"  
X.XXX ± 0.005"

**PROPRIETARY AND CONFIDENTIAL**  
THE INFORMATION CONTAINED IN THIS DRAWING IS PROVIDED FOR FRAMEBUILDERS AND IS THE PROPERTY OF PARAGON MACHINE WORKS. ANY REPRODUCTION IN PART OR AS A WHOLE WITHOUT THE WRITTEN PERMISSION OF PARAGON MACHINE WORKS IS PROHIBITED.

SIZE	DWG. NO.	REV
<b>A</b>	<b>DR4075</b>	<b>A1</b>

SCALE: 2:3

SHEET 2 OF 1