

**EXPLODED VIEW**

ITEM NO.	PART NO.	DESCRIPTION	MATERIAL
1	DS0004	Flat	6/4 Titanium
2	DR4074 (Bare) B4074 (Black)	ISO Mount	6061 Aluminum
3	MS1013	Double Washer	Stainless Steel
4	MS2012	M8 x 1.25 x 18 BHCS	Steel
5	MS2013	M5 x 0.8 SHCS	Steel
6	MS2016	M5 Hex Nut	Steel
7	MS5001	BRASS THUMB NUT	Brass

**COMPATIBLE FRAME COMPONENTS**

6/4 TITANIUM	17/4 STAINLESS	DESCRIPTION
DS0001	DS1001, DS1007	Flanged
DS0004	DS1004	Flat
DS0004BD	DS1004BD	Flat, Belt Drive

See website for additional inserts.  
Inserts and frame components  
sold separately.

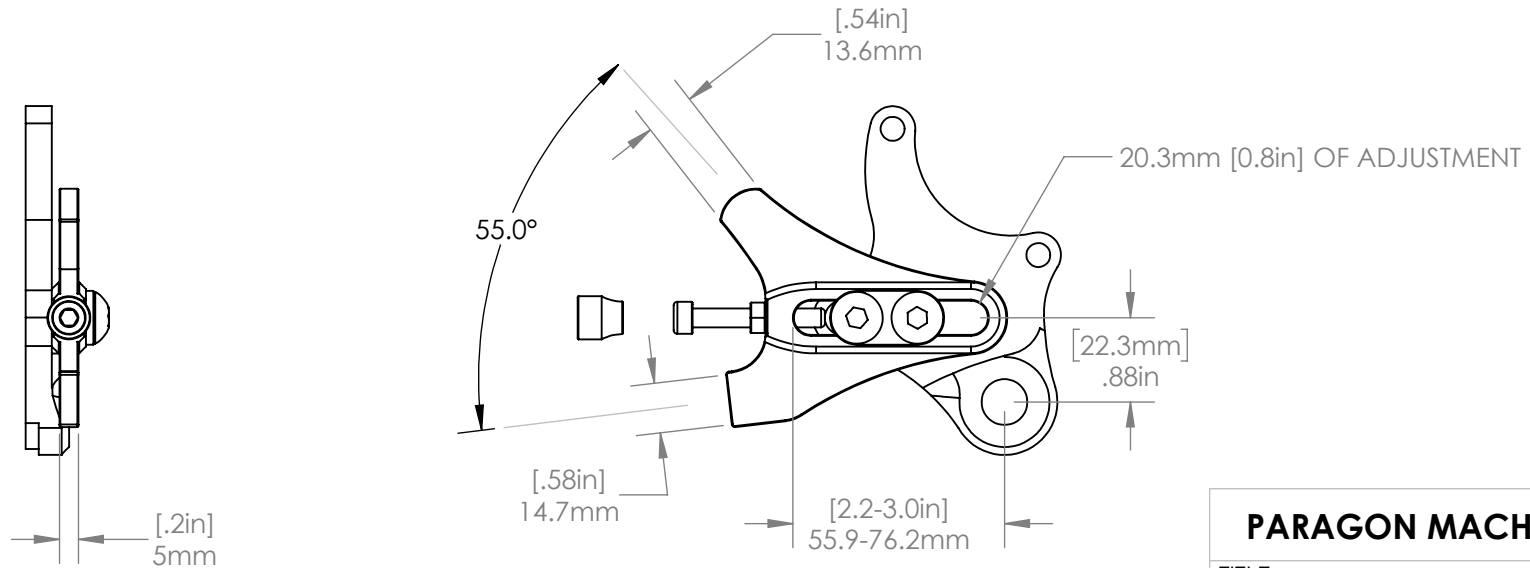
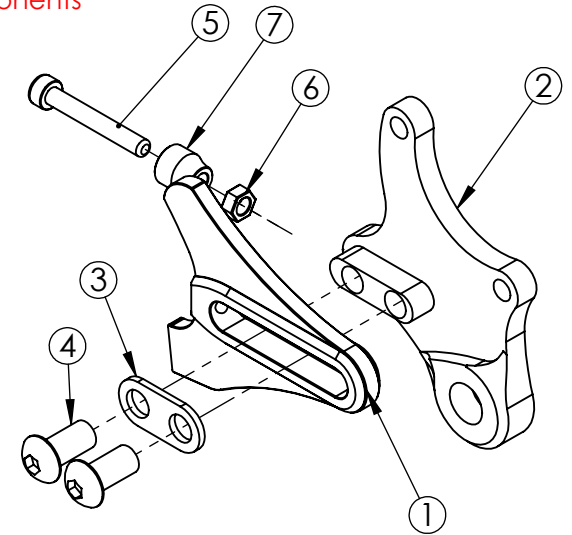

**PARAGON MACHINE WORKS**

TITLE:  
Left Side Insert, Sliding,  
ISO Mount,  
12 mm Hub

	NAME	DATE
DRAWN BY:	L.L	9/24

CHECKED BY:  
MATERIAL: 6061 ALUMINUM

GENERAL TOLERANCES

X.X ± 0.020"  
X.XX ± 0.010"  
X.XXX ± 0.005"

**PROPRIETARY AND  
CONFIDENTIAL**

THE INFORMATION CONTAINED IN THIS  
DRAWING IS PROVIDED FOR  
FRAMEBUILDERS AND IS THE PROPERTY OF  
PARAGON MACHINE WORKS. ANY  
REPRODUCTION IN PART OR AS A WHOLE  
WITHOUT THE WRITTEN PERMISSION OF  
PARAGON MACHINE WORKS IS PROHIBITED.

SIZE <b>A</b>	DWG. NO. <b>DR4074</b>	REV <b>A1</b>
------------------	---------------------------	------------------

SCALE: 2:3

SHEET 1 OF 1