

EXPLODED VIEW

ITEM NO.	PART NO.	DESCRIPTION	MATERIAL
1	DS0004	Flanged	6/4 Titanium
2	DR4050 (Bare) B4050 (Black)	Post Mount, 140 Rotor	6061 Aluminum
3	MS1013	Double Washer	Stainless Steel
4	MS2012	M8 x 1.25 x 18 BHCS	Zinc Plated Steel
5	MS2013	M5 x 0.8 SHCS	Steel
6	MS2016	M5 Hex Nut	Steel
7	MS5001	M5 Thumb Nut	Brass

COMPATIBLE FRAME COMPONENTS

6/4 TITANIUM	17/4 STAINLESS	DESCRIPTION
DS0001	DS1001	Flanged
DS0004	DS1004	Flat
DS0004BD	DS1004BD	Flat, Belt Drive

See website for additional inserts.
Inserts and frame components
sold separately.

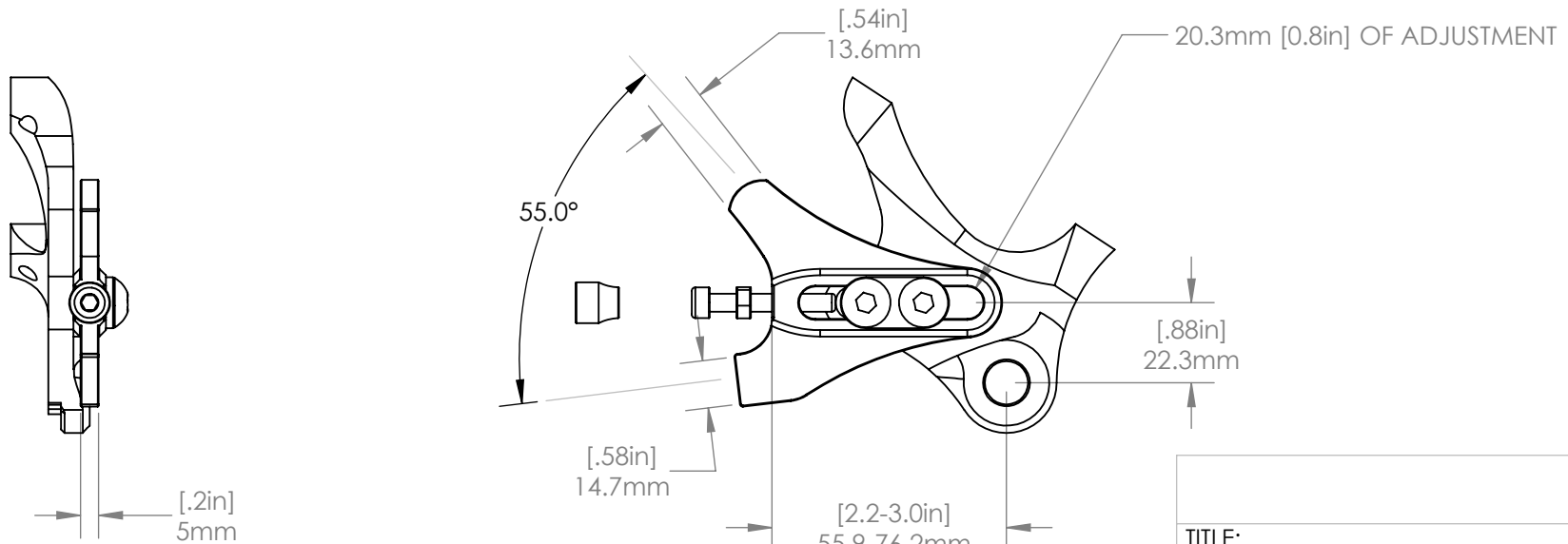
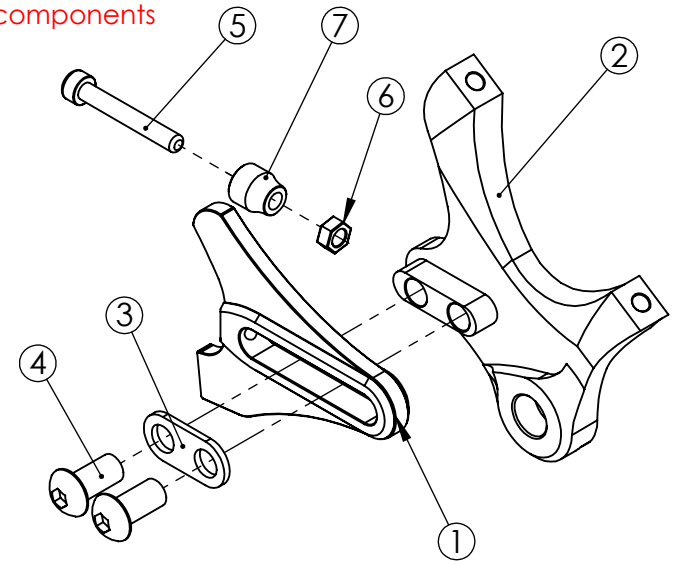

TITLE:
Left Side Insert, Sliding,
Post Mount, 140 Rotor,
12 mm Hub

	NAME	DATE
DRAWN BY:	CAN	8/2018
CHECKED BY:	MCN	8/2018

PROPRIETARY AND CONFIDENTIAL

THE INFORMATION CONTAINED IN THIS DRAWING IS PROVIDED FOR FRAMEBUILDERS AND IS THE PROPERTY OF PARAGON MACHINE WORKS. ANY REPRODUCTION IN PART OR AS A WHOLE WITHOUT THE WRITTEN PERMISSION OF PARAGON MACHINE WORKS IS PROHIBITED.

MATERIAL: 6061 ALUMINUM
GENERAL TOLERANCES
X.X ± 0.020"
X.XX ± 0.010"
X.XXX ± 0.005"

SIZE	DWG. NO.	REV
A	DR4050	A1
SCALE: 2:3		SHEET 1 OF 1