

UNTHREADED SIDE

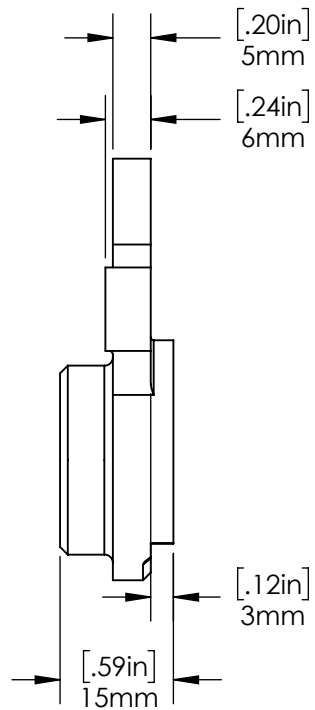

THREADED SIDE

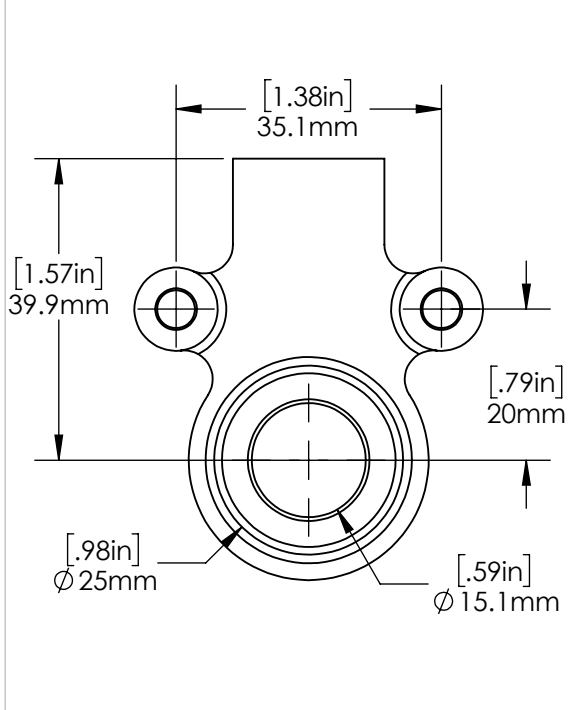
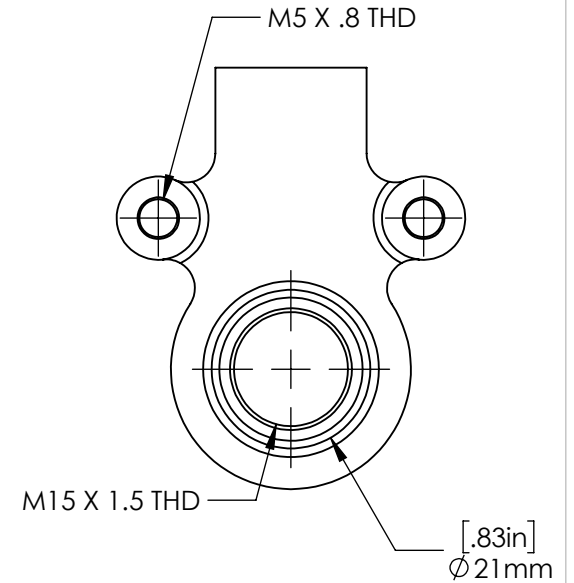
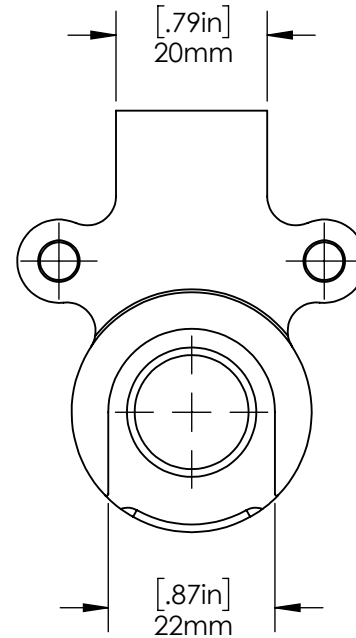

**PARAGON MACHINE WORKS**

TITLE:

15mm FRONT  
FLAT DROPOUT THRU AXLE  
WITH EYELETS

	NAME	DATE
DRAWN BY:	L.L	02/16
CHECKED BY:	MCN	02/16

**PROPRIETARY AND CONFIDENTIAL**

THE INFORMATION CONTAINED IN THIS DRAWING IS PROVIDED FOR FRAMEBUILDERS AND IS THE PROPERTY OF PARAGON MACHINE WORKS. ANY REPRODUCTION IN PART OR AS A WHOLE WITHOUT THE WRITTEN PERMISSION OF PARAGON MACHINE WORKS IS PROHIBITED.

MATERIAL:  
GENERAL TOLERANCES:  
X.X ± 0.020"  
X.XX ± 0.010"  
X.XXX ± 0.005"

SIZE	DWG. NO.	REV
<b>A</b>	<b>DR2058U</b>	<b>A1</b>

SCALE: 1:1

SHEET 1 OF 1