

## HANGER OPTIONS

PART #	THREAD	DESCRIPTION
B4079/DR4079	M12 x 1.5	NO HANGER
B4080/DR4080	M12 x 1.5	HANGER
B4081/DR4081	M12 x 1.5	SHIMANO DM MOUNTAIN
B4083/DR4083	M12 x 1.5	SHIMANO DM ROAD
B4191/DR4191	M12 x 1.5	SRAM DERAILLEUR

PART #	MATERIAL	DESCRIPTION
DR0032	6/4 Titanium	48° Eyelets
DR1032	17/4 Stainless	48° Eyelets
DR2032	4130 Steel	48° Eyelets
DR0033	6/4 Titanium	58° Eyelets
DR1033	17/4 Stainless	58° Eyelets
DR2033	4130 Steel	58° Eyelets
DR0036	6/4 Titanium	48° No Eyelets
DR1036	17/4 Stainless	48° No Eyelets
DR2036	4130 Steel	48° No Eyelets
DR0037	6/4 Titanium	58° No Eyelets
DR1037	17/4 Stainless	58° No Eyelets
DR2037	4130 Steel	58° No Eyelets

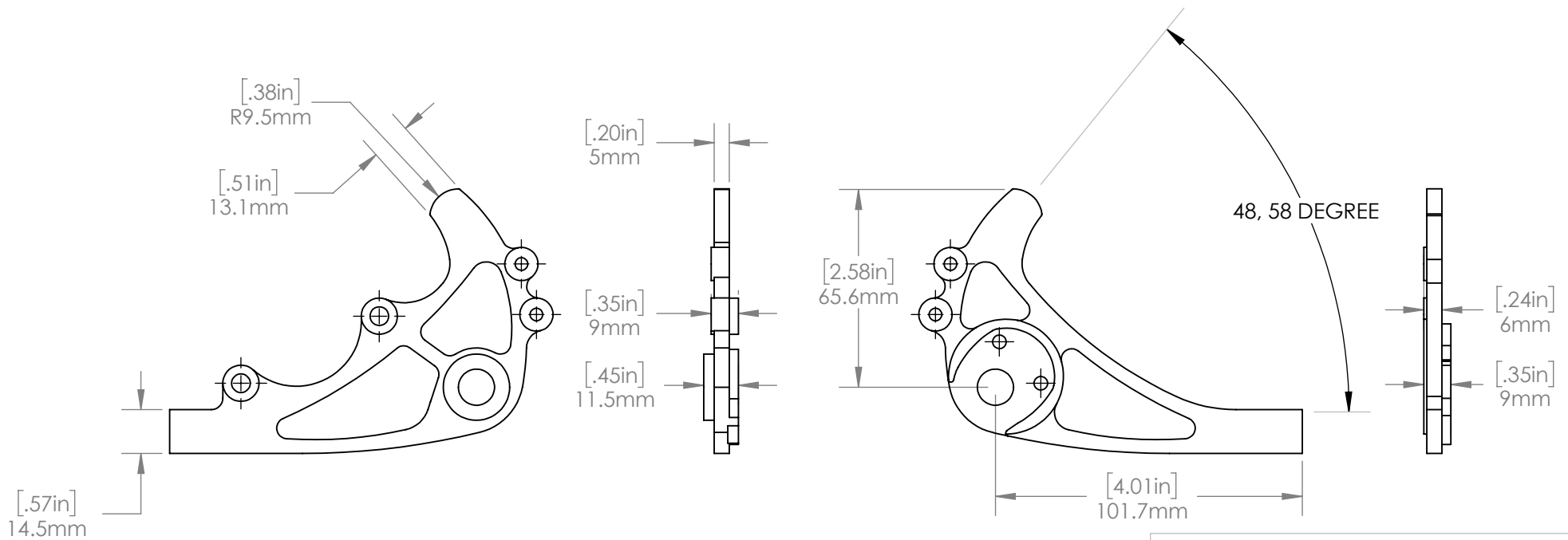

## PARAGON MACHINE WORKS

TITLE:

48, 58 DEGREE 12 MM LOW  
MOUNT DROPOUT  
EYELETS, NO EYELETS

SIZE	DWG. NO.	REV
A	DR203X	A

SCALE: 1:2

SHEET 1 OF 1

	NAME	DATE
DRAWN BY:	DN	9/2018
CHECKED BY:	MCN	9/2018

### PROPRIETARY AND CONFIDENTIAL

THE INFORMATION CONTAINED IN THIS DRAWING IS PROVIDED FOR FRAMEBUILDERS AND IS THE PROPERTY OF PARAGON MACHINE WORKS. ANY REPRODUCTION IN PART OR AS A WHOLE WITHOUT THE WRITTEN PERMISSION OF PARAGON MACHINE WORKS IS PROHIBITED.

MATERIAL:  
GENERAL TOLERANCES:  
X.X ± 0.020"  
X.XX ± 0.010"  
X.XXX ± 0.005"