

PART NO.	MATERIAL	LENGTH (L)
BB4039	6061	68MM (2.677")
BB4041	6061	73MM (2.874")
BB4040	7005	69MM (2.716")
BB4042	7005	74MM (2.913")

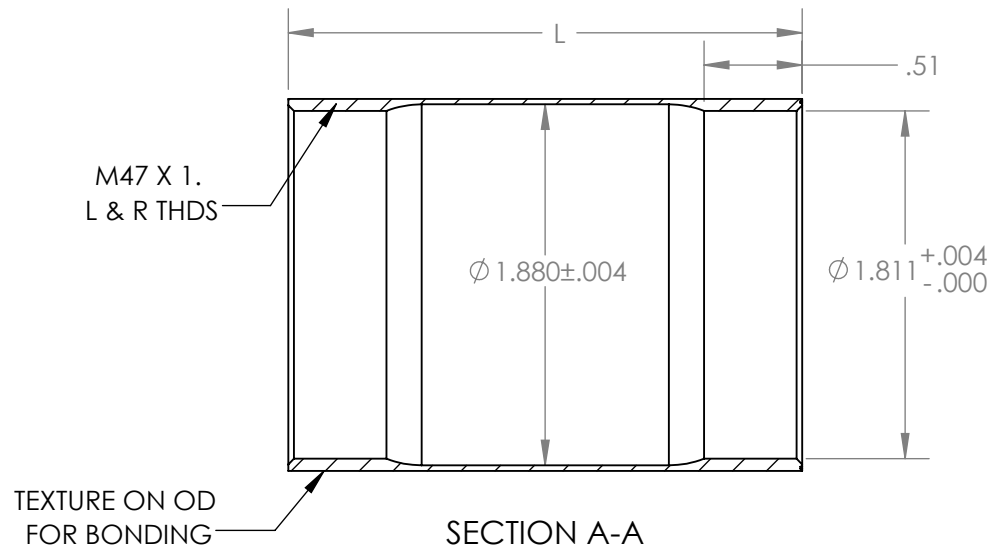
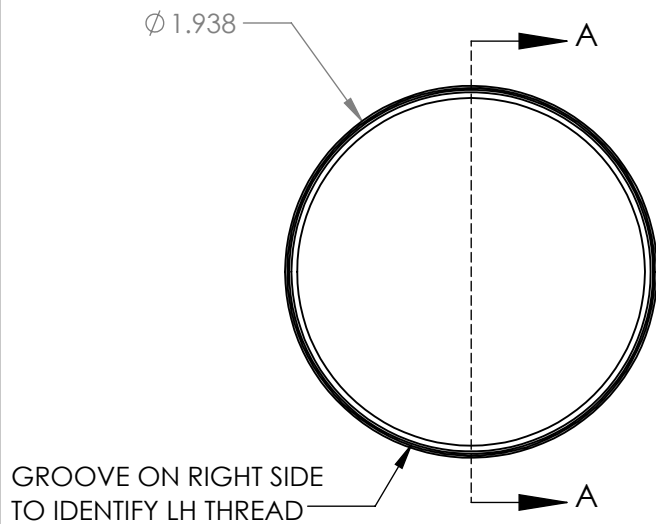

**PARAGON MACHINE WORKS**

TITLE:  
**T47 BOTTOM BRACKET SHELL**

	NAME	DATE
DRAWN BY:	L.L	01/16
CHECKED BY:		

**PROPRIETARY AND CONFIDENTIAL**

THE INFORMATION CONTAINED IN THIS DRAWING IS PROVIDED FOR FRAMEBUILDERS AND IS THE PROPERTY OF PARAGON MACHINE WORKS. ANY REPRODUCTION IN PART OR AS A WHOLE WITHOUT THE WRITTEN PERMISSION OF PARAGON MACHINE WORKS IS PROHIBITED.

**MATERIAL:**  
**GENERAL TOLERANCES:**  
X.X ± 0.020"  
X.XX ± 0.010"  
X.XXX ± 0.005"

SIZE	DWG. NO.	REV
<b>A</b>	<b>BB4039</b>	<b>A2</b>
SCALE: 1:1		SHEET 1 OF 1