

Finished Width	L		Part #
	Actual Width	Decimal Equivalent	
68 mm	69 mm	2.716"	BB0050
73 mm	74 mm	2.913"	BB0052
86.5 mm	87.5 mm	3.444"	BB0055
91.5 mm	92.5 mm	3.642"	BB0059

2-1/16" STOCK OD

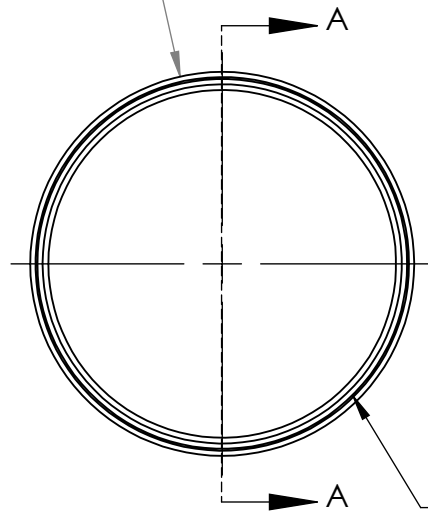

GROOVE ON RIGHT SIDE
TO IDENTIFY LH THREAD

M47 X1.
L & R THDS

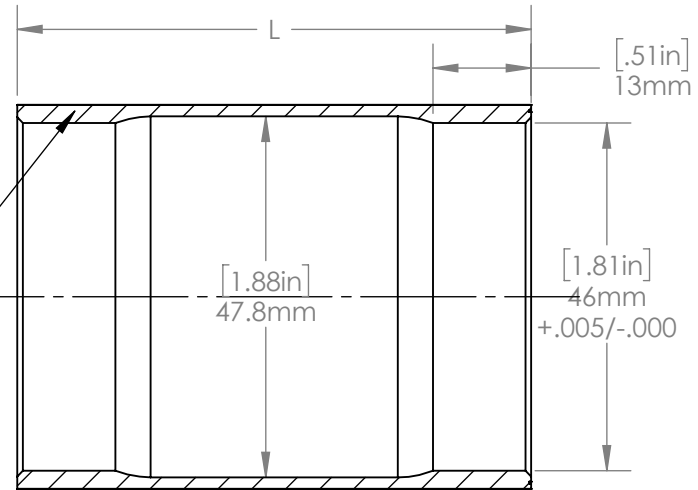

SECTION A-A

* TEXTURED FINISH ON OD
FOR BONDING

PARAGON MACHINE WORKS

TITLE:

**T47 BOTTOM BRACKET
SHELL**

	NAME	DATE
DRAWN BY:	DN	8/2020
CHECKED BY:	MCN	8/2020

MATERIAL:
GENERAL TOLERANCES:
X.X ± 0.020"
X.XX ± 0.010"
X.XXX ± 0.005"

SIZE	DWG. NO.	REV
A	BB0050	A1

SCALE: 1:1

SHEET 1 OF 1

**PROPRIETARY AND
CONFIDENTIAL**

THE INFORMATION CONTAINED IN THIS
DRAWING IS PROVIDED FOR
FRAMEBUILDERS AND IS THE PROPERTY OF
PARAGON MACHINE WORKS. ANY
REPRODUCTION IN PART OR AS A WHOLE
WITHOUT THE WRITTEN PERMISSION OF
PARAGON MACHINE WORKS IS PROHIBITED.