

WIDTH (MM)	OD (IN)	MATERIAL	PART #
68.5	1-1/2	4130 STEEL	BB2007 BB2007H
		17/4 STAINLESS	BB1001
		3/2.5 TITANIUM	BB0001
	1-9/16	4130 STEEL	BB2011
		3/2.5 TITANIUM	BB0021
	1-5/8	3/2.5 TITANIUM	BB0023
73.5	1-1/2	4130 STEEL	BB2008
		17/4 STAINLESS	BB1002
	1-9/16	4130 STEEL	BB2012
		3/2.5 TITANIUM	BB0022
	1-5/8	3/2.5 TITANIUM	BB0024
83.5	1-1/2	4130 STEEL	BB2009
	1-9/16	3/2.5 TITANIUM	BB0017
100.5	1-1/2	4130 STEEL	BB2010
		17/4 STAINLESS	BB1018
	1-9/16	3/2.5 TITANIUM	BB0018
110.5	1-1/2	4130 STEEL	BB2014
120	1-1/2	4130 STEEL	BB2013

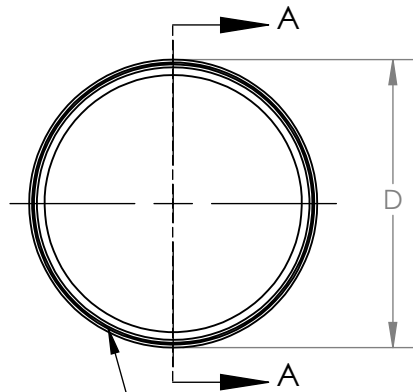

GROOVE ON RIGHT SIDE TO IDENTIFY LH THREAD

1.370-24 L&R THD

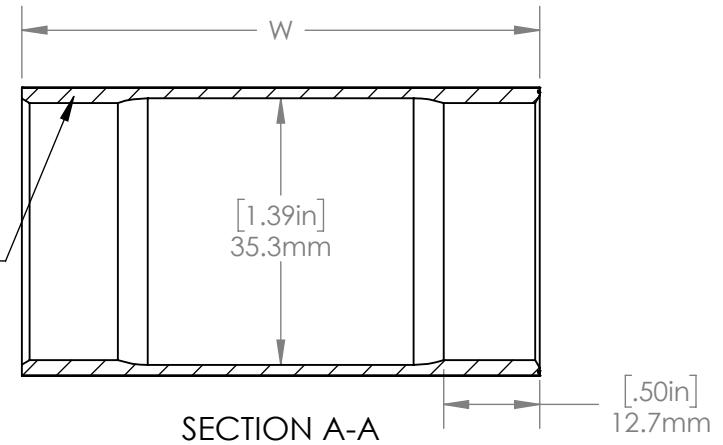

SECTION A-A

PARAGON MACHINE WORKS

TITLE:

**THREADED
BOTTOM BRACKET SHELL**

	NAME	DATE
DRAWN BY:	DN	6/2019
CHECKED BY:	MCN	6/2019

MATERIAL:
GENERAL TOLERANCES:
X.X 0.020"
X.XX 0.010"
X.XXX 0.005"

SIZE	DWG. NO.	REV
A	BB0001	A1

SCALE: 1:1

SHEET 1 OF 1

**PROPRIETARY AND
CONFIDENTIAL**

THE INFORMATION CONTAINED IN THIS DRAWING IS PROVIDED FOR FRAMEBUILDERS AND IS THE PROPERTY OF PARAGON MACHINE WORKS. ANY REPRODUCTION IN PART OR AS A WHOLE WITHOUT THE WRITTEN PERMISSION OF PARAGON MACHINE WORKS IS PROHIBITED.