

PART NO.	DESCRIPTION	L1	L2
SK4075	142 X M12 X 1	6.417in [163mm]	5.827in [148mm]
SK4076	148 X M12 X 1	6.654in [169mm]	6.063in [154mm]
SK4077	157 x M12 x 1	6.996in [178mm]	6.417in [163mm]
SK4078	177 x M12 x 1	7.783in [198mm]	7.205in [183mm]
SK4079	197 x M12 x 1	8.571in [218mm]	7.992in [203mm]

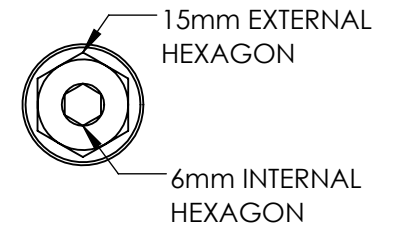
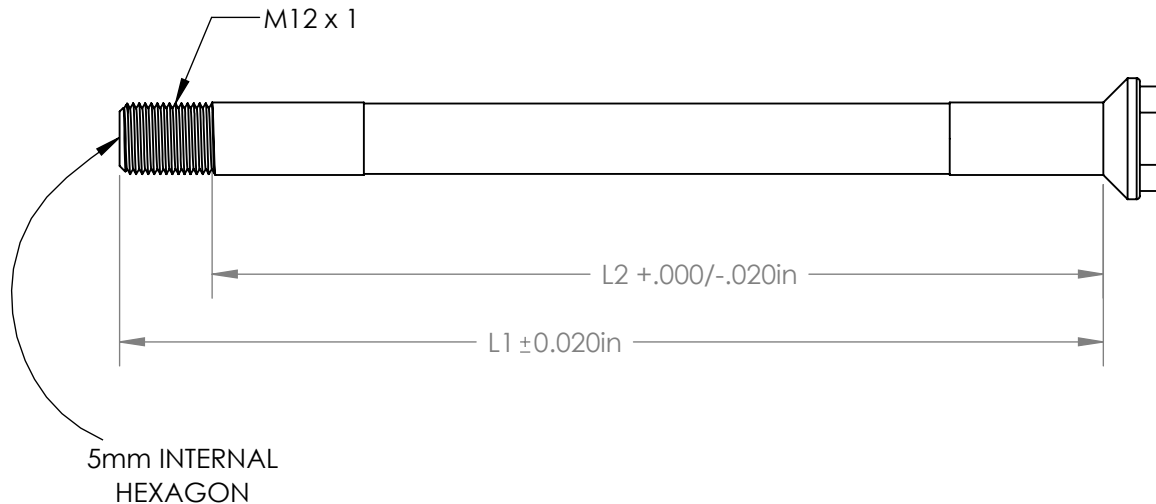
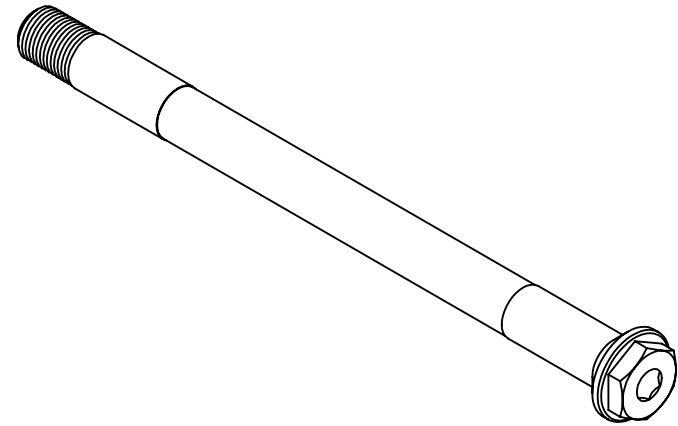

PARAGON MACHINE WORKS

TITLE: PMW COMBINATION
HEAD REAR SKEWER
SYNTACE

	NAME	DATE
DRAWN BY:	L.L	10/2021
CHECKED BY:	MCN	10/2021

PROPRIETARY AND CONFIDENTIAL

THE INFORMATION CONTAINED IN THIS DRAWING IS PROVIDED FOR FRAMEBUILDERS AND IS THE PROPERTY OF PARAGON MACHINE WORKS. ANY REPRODUCTION IN PART OR AS A WHOLE WITHOUT THE WRITTEN PERMISSION OF PARAGON MACHINE WORKS IS PROHIBITED.

MATERIAL:
GENERAL TOLERANCES:
X.X ± 0.020"
X.XX ± 0.010"
X.XXX ± 0.005"

SIZE	DWG. NO.	REV
A	SK4077	A1

SCALE: 1:1.25

SHEET 1 OF 2