

PART NUMBER		LENGTH (MM)
TIITANIUM	STEEL	
HT0300		95
HT0302	HT2302	100
HT0304		105
HT0306	HT2306	110
HT0308		115
HT0310	HT2310	120
HT0312		125
HT0314	HT2314	130
HT0316		135
HT0318	HT2318	140
HT0320		145
HT0322	HT2322	150
HT0324		155
HT0326	HT2326	160
HT0328		165
HT0330	HT2330	170
HT0332		175
HT0334	HT2334	180
HT0336		185
HT0338	HT2338	190
HT0340		195
HT0342	HT2342	200
HT0346		210
HT0350		220
HT0354		230

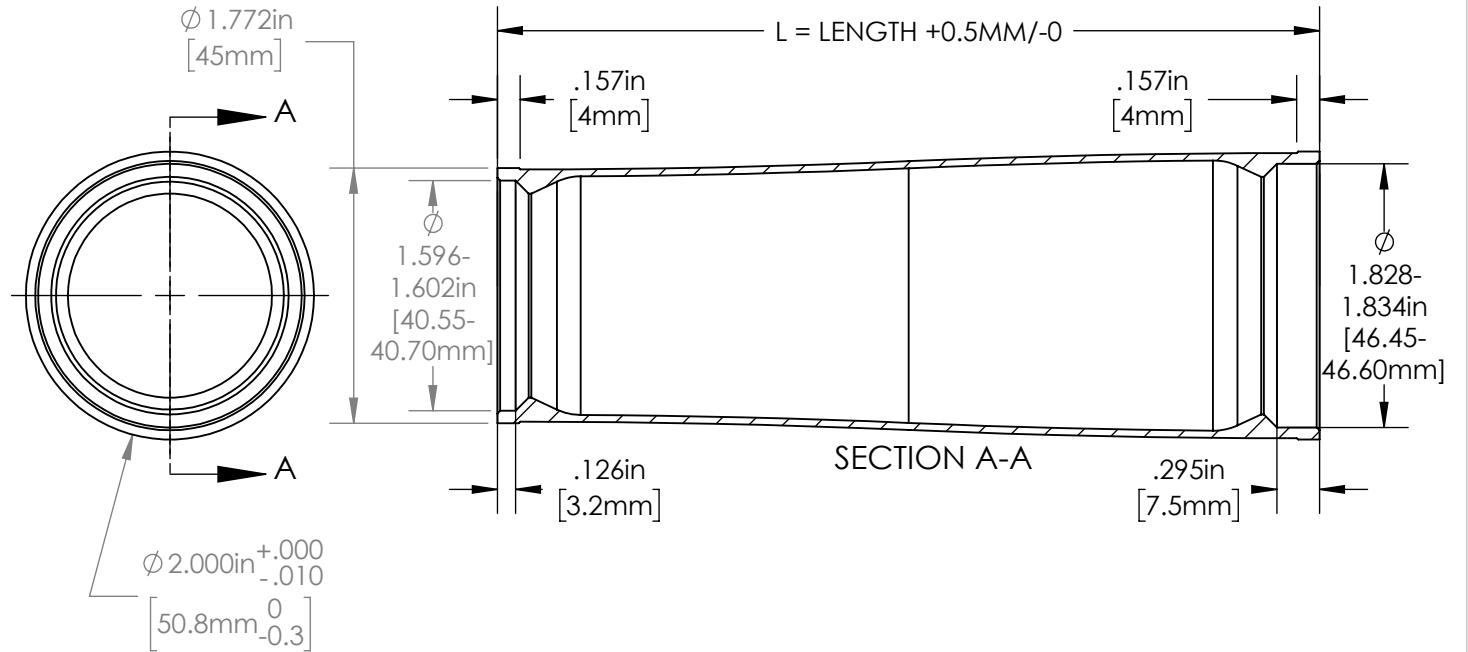

PARAGON MACHINE WORKS

TITLE:
IS41/IS47 INTEGRATED
TAPERED HEADTUBES

	NAME	DATE
DRAWN BY:	DN	9/2017
CHECKED BY:	MCN	9/2017

MATERIAL:
GENERAL TOLERANCES:
X.X ± 0.020"
X.XX ± 0.010"
X.XXX ± 0.005"

SIZE	DWG. NO.	REV
A	HT03XX	

SCALE: 1:1

SHEET 1 OF 1

**PROPRIETARY AND
CONFIDENTIAL**

THE INFORMATION CONTAINED IN THIS DRAWING IS PROVIDED FOR FRAMEBUILDERS AND IS THE PROPERTY OF PARAGON MACHINE WORKS. ANY REPRODUCTION IN PART OR AS A WHOLE WITHOUT THE WRITTEN PERMISSION OF PARAGON MACHINE WORKS IS PROHIBITED.