

PART NUMBER TITANIUM	PART NUMBER STEEL	LENGTH (L) MM
HT0001	HT2001	90
HT0002	HT2002	95
HT0003	HT2004	100
HT0005	HT2005	105
HT0006	HT2006	110
HT0007	HT2007	115
HT0008	HT2008	120
HT0009	HT2009	125
HT0010	HT2010	130
HT0011	HT2011	135
HT0012	HT2012	140
HT0013	HT2013	145
HT0014	HT2014	150
HT0015	HT2015	155
HT0016	HT2016	160
HT0017	HT2017	165
HT0018	HT2018	170
HT0019	HT2019	175
HT0020	HT2020	180
HT0021	HT2021	185
HT0022	HT2022	190
HT0023	HT2023	195
HT0024	HT2024	200
HT0026	N/A	210
HT0028	HT2025	220
HT0030	HT2026	230
HT0032	N/A	240
HT0034	HT2030	250
HT0036	N/A	260
HT0038	N/A	270
HT0039	N/A	275
HT0040	HT2035	280

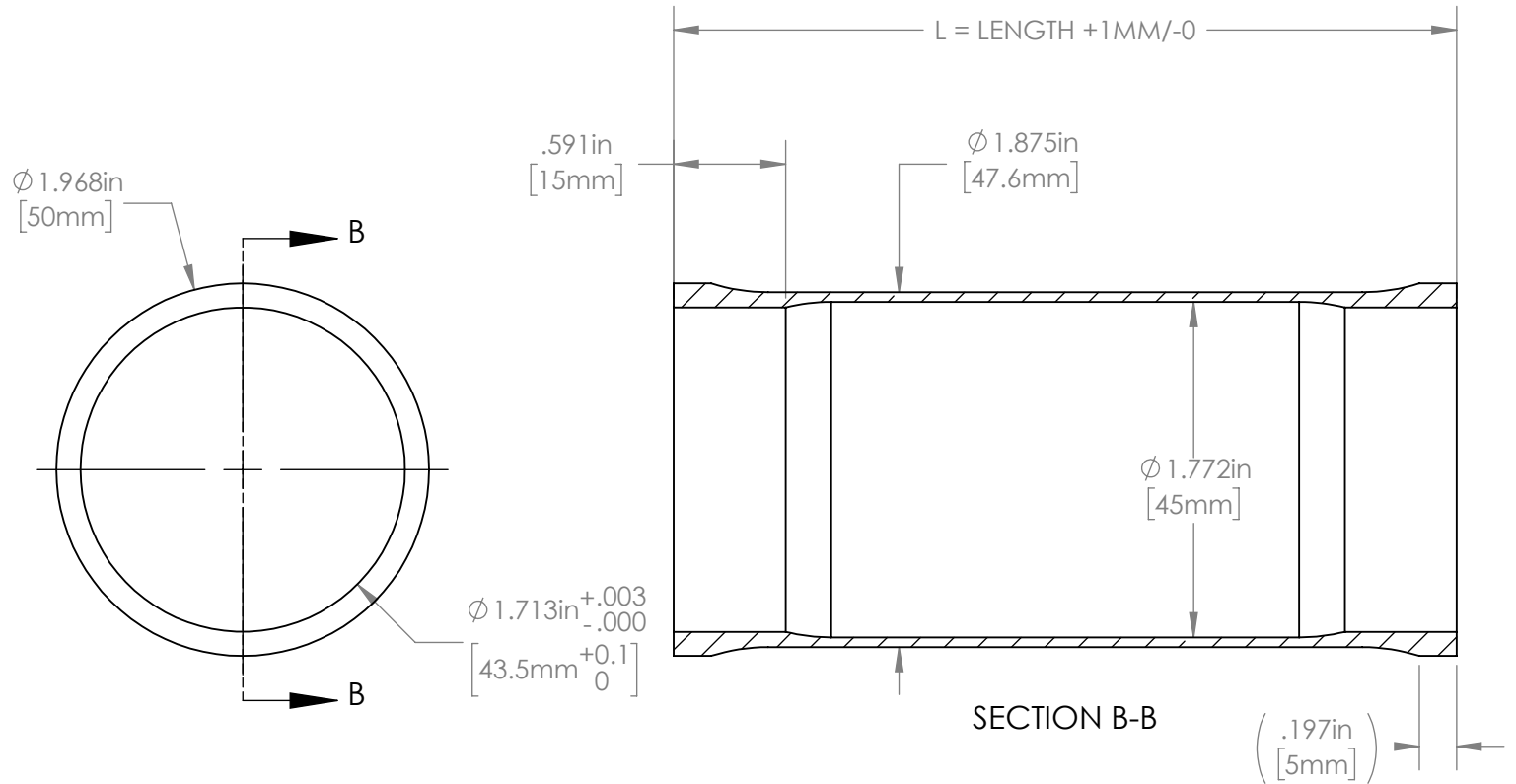

PARAGON MACHINE WORKS

TITLE:
**44MM HEADTUBE
 SINGLE COLLAR
 1-7/8" X 50 MM OD**

	NAME	DATE
DRAWN BY:	DN	8/2017
CHECKED BY:	MCN	8/2017

MATERIAL:
GENERAL TOLERANCES:
 X.X ± 0.020"
 X.XX ± 0.010"
 X.XXX ± 0.005"

SIZE	DWG. NO.	REV
A	HT00XX	A1

**PROPRIETARY AND
 CONFIDENTIAL**

THE INFORMATION CONTAINED IN THIS DRAWING IS PROVIDED FOR FRAMEBUILDERS AND IS THE PROPERTY OF PARAGON MACHINE WORKS. ANY REPRODUCTION IN PART OR AS A WHOLE WITHOUT THE WRITTEN PERMISSION OF PARAGON MACHINE WORKS IS PROHIBITED.