

SECTION A-A

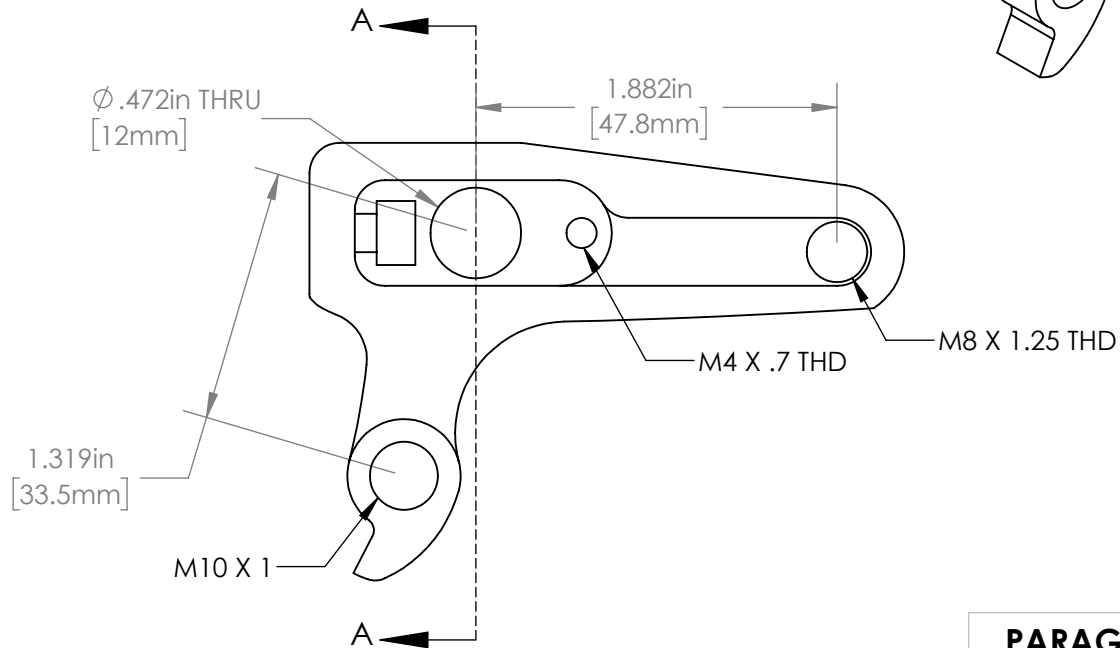
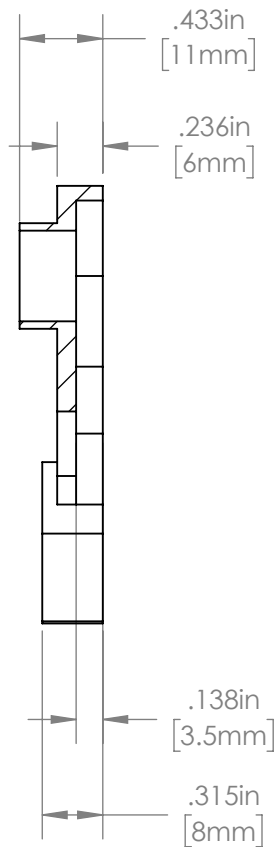

PARAGON MACHINE WORKS

TITLE:
**RIGHT SIDE INSERT FOR
 DEDICATED 12MM
 DROPOUT SRAM HANGER**

	NAME	DATE
DRAWN BY:	L.L	9/20
CHECKED BY:		

**PROPRIETARY AND
 CONFIDENTIAL**
 THE INFORMATION CONTAINED IN THIS
 DRAWING IS PROVIDED FOR
 FRAMEBUILDERS AND IS THE PROPERTY OF
 PARAGON MACHINE WORKS. ANY
 REPRODUCTION IN PART OR AS A WHOLE
 WITHOUT THE WRITTEN PERMISSION OF
 PARAGON MACHINE WORKS IS PROHIBITED.

MATERIAL:
GENERAL TOLERANCES:
 X.X ± 0.020"
 X.XX ± 0.010"
 X.XXX ± 0.005"

SIZE	DWG. NO.	REV
A	DR4068	A1

SCALE: 1:1

SHEET 1 OF 1