

COMPATIBLE DROPOUTS	
1-1/2" ROUND, REAR (SHOWN)	MATERIAL
DR0065	6/T TITANIUM
DR1065	17/4 STAINLESS
DR2065	1018 STEEL
LOW MOUNT	MATERIAL
DR2032 DR2033 DR2036 DR2037	4130 STEEL
FLAT MOUNT	MATERIAL
DR0085 DR0086	6/4 TITANIUM
DR1085 DR1086	17/4 STAINLESS STEEL
DR2085 DR2086	4130 STEEL

12 mm INSERT OPTIONS, 6061 ALUMINUM		
PART NUMBER	SKEWER THREAD	DT SWISS
B4038 DR4038	M12 X 1	HANGER
B4040 DR4040	M12 X 1	NO HANGER
PART NUMBER		SRAM
B4091 DR4091	M12 X 1	HANGER (SHOWN)
PART NUMBER		SHIMANO
B4035 DR4035	NO THREAD	HANGER, WITH NUT/RETAINER
B4036 DR4036	NO THREAD	NO HANGER, WITH NUT/RETAINER
B4033 DR4033	NO THREAD	DIRECT MOUNT MTN HANGER, WITH NUT/RETAINER
B4081 DR4081	M12 X 1.5	DIRECT MOUNT MTN HANGER, NO NUT/RETAINER
B4083 DR4083	M12 X 1.5	DIRECT MOUNT ROAD HANGER, NO NUT/RETAINER
B4080 DR4080	M12 X 1.5	HANGER, NO NUT/RETAINER
B4079 DR4079	M12 X 1.5	NO HANGER, NO NUT/RETAINER

EXPLODED VIEW

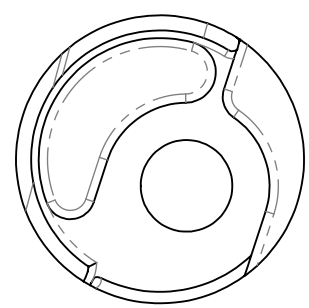
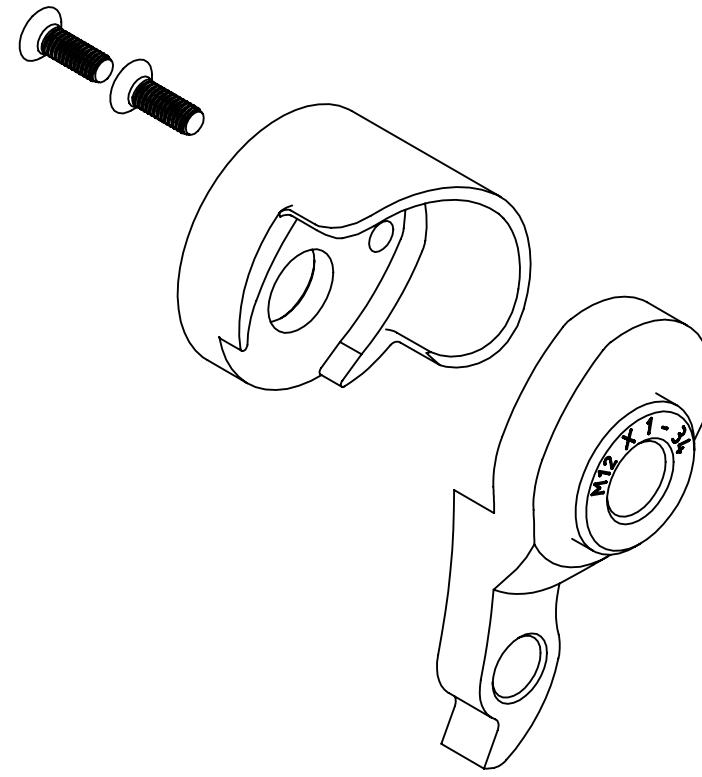

DIMENSION CHANGES WITH INSERT
SEE WEBSITE FOR DETAILS

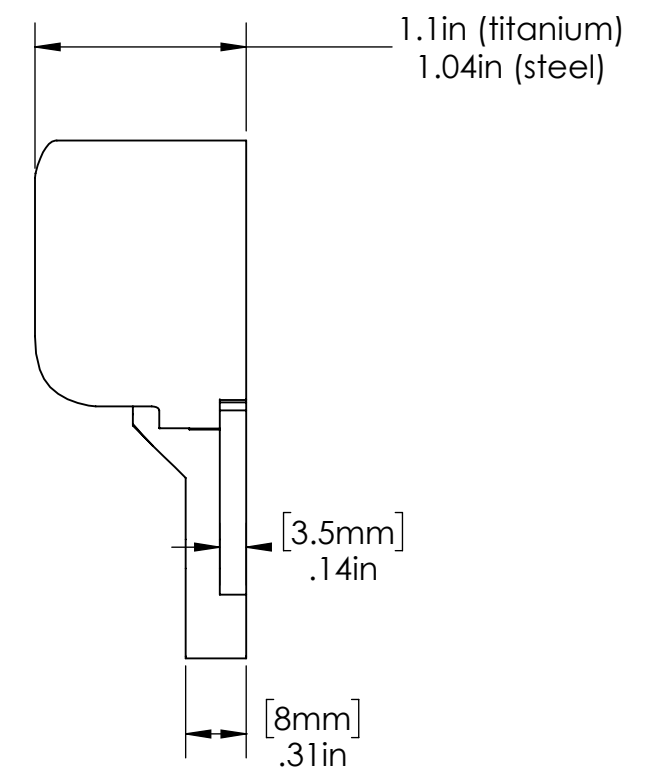
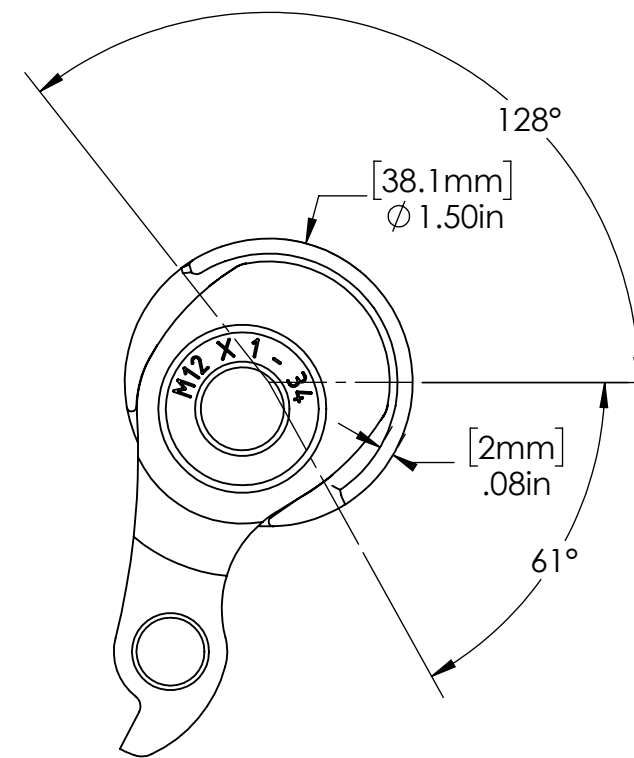
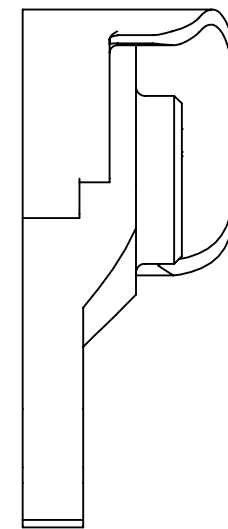
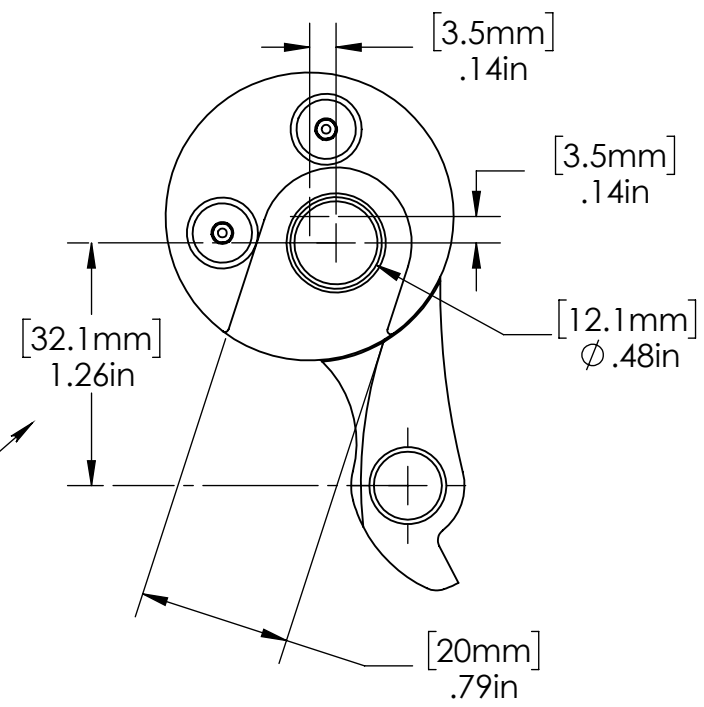

	NAME	DATE
DRAWN	DN	2/2018
CHECKED	MCN	2/2018

Paragon Machine Works		
TITLE: INSERTS FOR 1-1/2" ROUND, FLAT MOUNT, AND LOW MOUNT REAR DROPOUTS		
SIZE	DWG. NO.	REV
C	DR0065_INSERTS	
SCALE: 1:5		SHEET 1 OF 1

PROPRIETARY AND CONFIDENTIAL
THE INFORMATION CONTAINED IN THIS DRAWING IS PROVIDED FOR FRAMEBUILDERS AND IS THE SOLE PROPERTY OF PARAGON MACHINE WORKS. ANY REPRODUCTION IN PART OR AS A WHOLE WITHOUT THE WRITTEN PERMISSION OF PARAGON MACHINE WORKS IS PROHIBITED.